

THE INFORMATION CONTAINED IN THIS DRAWING IS THE SOLE PROPERTY OF L&T PRECISION SHEET METAL CORP. ANY REPRODUCTION IN PART OR WHOLE WITHOUT THE WRITTEN PERMISSION OF L&T PRECISION SHEET METAL CORP. IS PROHIBITED.

REVISIONS			
REV.	DESCRIPTION	DATE	APPROVED

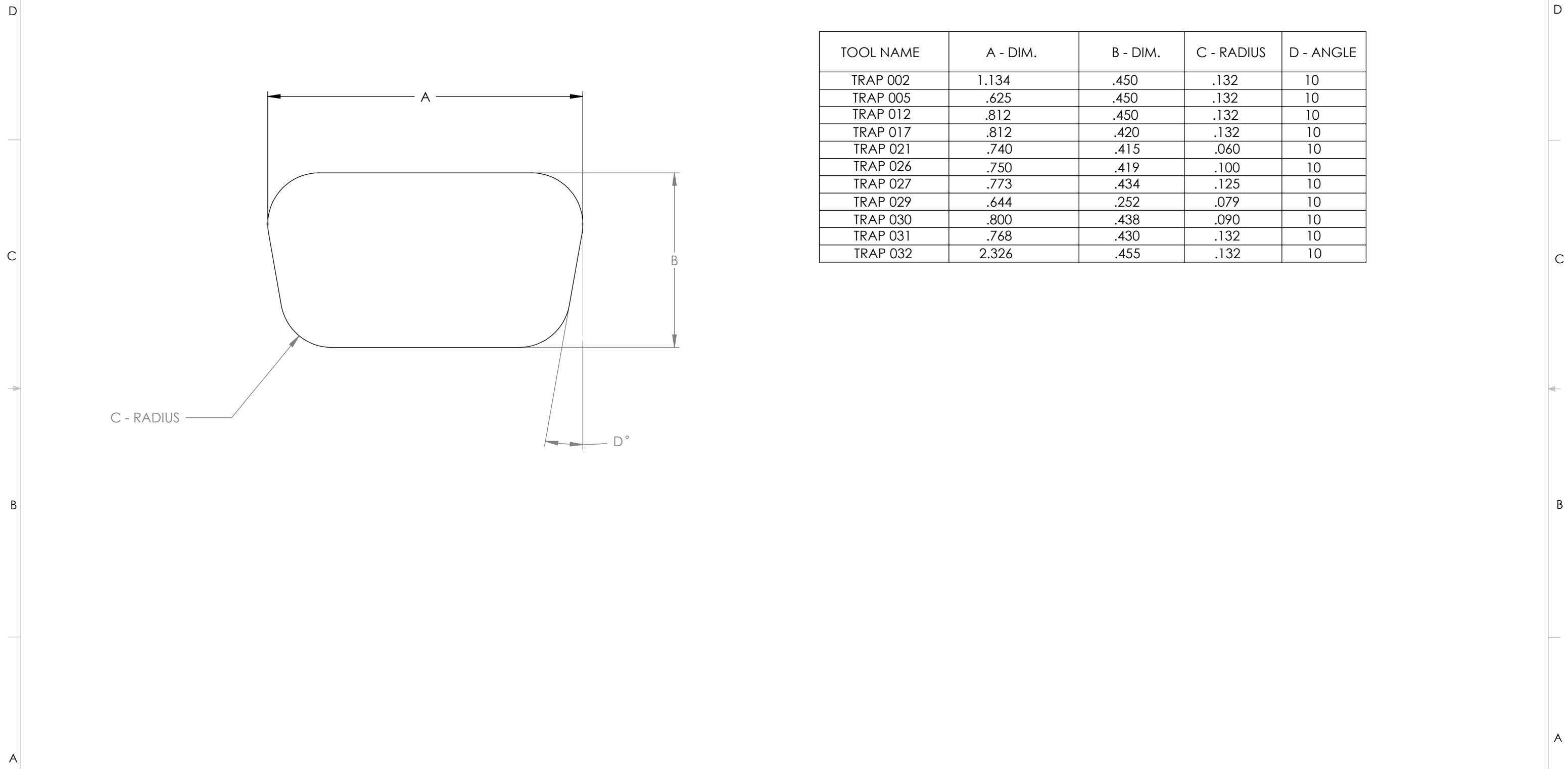

TOOL NAME	A - DIM.	B - DIM.	C - RADIUS	D - ANGLE
TRAP 002	1.134	.450	.132	10
TRAP 005	.625	.450	.132	10
TRAP 012	.812	.450	.132	10
TRAP 017	.812	.420	.132	10
TRAP 021	.740	.415	.060	10
TRAP 026	.750	.419	.100	10
TRAP 027	.773	.434	.125	10
TRAP 029	.644	.252	.079	10
TRAP 030	.800	.438	.090	10
TRAP 031	.768	.430	.132	10
TRAP 032	2.326	.455	.132	10

UNLESS OTHERWISE SPECIFIED DIMENSIONS ARE IN INCHES. TOLERANCES ARE:		CAD GENERATED DRAWING, DO NOT MANUALLY UPDATE		L&T Precision Sheet Metal Corp.	
FRACTIONS	DECIMALS	ANGLES	APPROVALS		
± 1/32	.X ±.1 .XX ±.03 .XXX ±.010	± 1/2°	DRAWN TT	06-12-07	TRAPZOIED TOOL LIST
DO NOT SCALE DRAWING		CHECKED		REV. A	
MATERIAL	AAA	APPROVED		SIZE B	PART NUMBER AAA
BD:	AAA	SCALE		CAD FILE:	SHEET 1 OF 1